



SOLUTIONS FOR CONSERVATION
AREAS & LISTED BUILDINGS

THE
RESIDENCE
COLLECTION





Authentic Timber Alternative



19TH CENTURY
DESIGN

The Residence Collection & Sustainability

As a company we are putting sustainability at the forefront of our business, our head office has achieved a zero-landfill mark, we're well on our way to making company vehicles electric and achieve our target to become carbon neutral by 2025. Also, all uPVC windows and doors can be fully recycled up to 10 times and included within The Residence Collection is a 100% recycled material section. The Residence Collection windows and doors can also contribute to lower energy bills and carbon emissions due to their outstanding thermal performance.

Heritage Design for 21st Century Living

The design brief for The Residence Collection was to extract the key principles, shapes and dimensions from Article 4 directions for windows, and integrate market leading technology into the design using virtually maintenance free materials; your windows and doors won't warp, swell, flake or need sanding and painting, ever! The Residence Collection offers a suite of thermally and acoustically superior window and door systems, featuring the latest security, maintenance and performance innovations, whilst still appearing traditional. A beautiful addition to your home.

WHAT ARE ARTICLE 4 DIRECTIONS & DO THEY APPLY TO MY HOME?

Article 4 directions are made by the local planning authority, and this can affect you when installing windows in your home. They restrict the scope of permitted development rights, either in relation to a particular area or site, or a particular type of development anywhere in the authority's area. Article 4 directions are used to control works that could threaten the character and architectural merit of an area or building of acknowledged importance. This means that new windows and doors *may* need planning permission. Windows are the defining feature and focal point of any building and the type of window installed can improve or completely ruin the look of a building, which is important in conservation areas or listed buildings.

WHAT IS A CONSERVATION AREA?

An area "of special architectural or historic interest, the character or appearance of which it is desirable to preserve or enhance". Many of our towns, villages and cities rely on correctly specified windows for much of their architectural impact and character. Inappropriate, poor quality replacement windows can easily erode traditional features on historic buildings.

WHAT IS A LISTED BUILDING?

Listing is not a preservation order, preventing change. It does not freeze a building in time, it simply means that listed building consent must be applied for in order to make any changes to that building, which might affect its special interest. It's there to protect the aesthetic of that building.

HOW DOES THE RESIDENCE COLLECTION FIT INTO THIS?

A more modern approach has been for planning authorities to approve the use of The Residence Collection in conservation areas because of its authentic design. It has been specifically designed to aesthetically replicate the documented historical window designs from the 19th Century period (read on in the brochure to see proof of this!) and therefore has been approved for use in many areas across the UK. The Residence Collection has also been fitted in some listed buildings, however the local authority uses listed building consent to make decisions that balance the site's historic significance against other issues, such as its function, condition or viability. With listed building consent it is not always just about the aesthetic, it can sometimes be about the material choices too.

Please note, you should always obtain planning permission from the Local Planning Authority before commencing work.



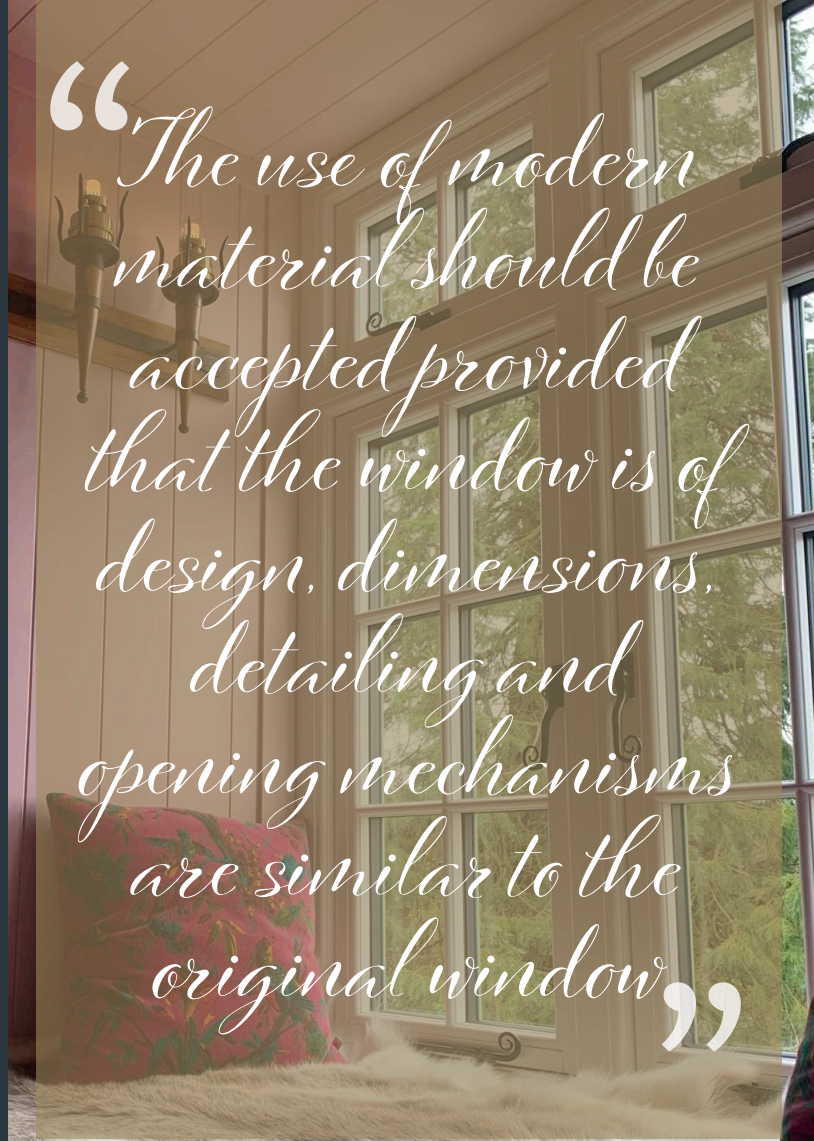

“The use of modern material should be accepted provided that the window is of design, dimensions, detailing and opening mechanisms are similar to the original window.”

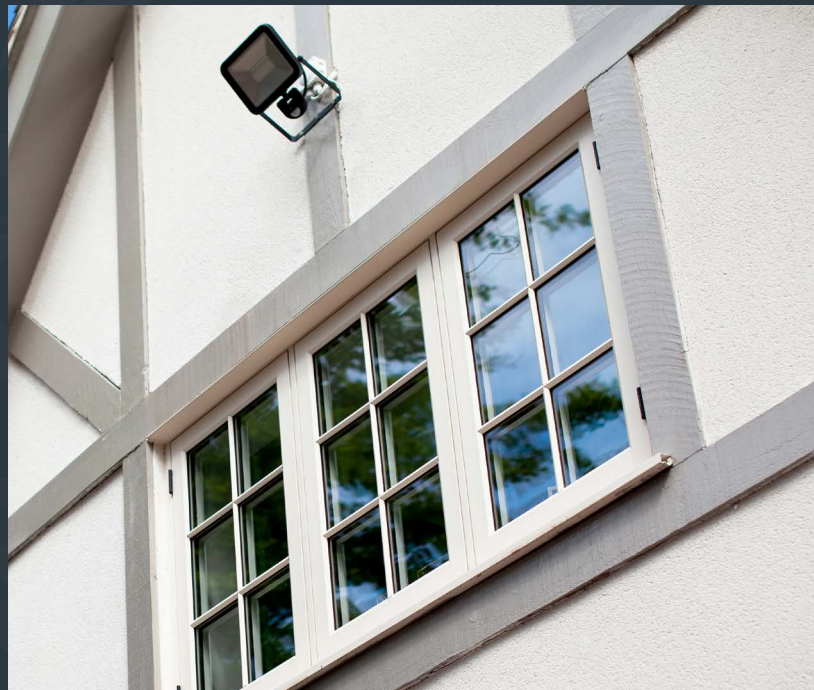



Clotted Cream

Afternoon tea wouldn't be complete without it! Clotted Cream is a pretty, traditional colour, which creates delightfully inviting homes with a gentle warmth.

“We wanted performance and style, but our property also comes under a Conservation Area so it was vital that we adhered to the council regulations. R9 was the perfect choice for us.”

R9





*Did You Know?
Around 2.2% of
England is made up of
Conservation Areas -
That's an area larger
than Luxembourg!**

*Source <https://historicengland.org.uk>

RI



Painswick

Named in honour of the historic wool town set in the Cotswold Hills, with a nod to the traditional era of Downton Abbey! The modest grey green of Painswick has become one of our most popular finishes in recent years. This rather indeterminate colour brings a softness to homes.

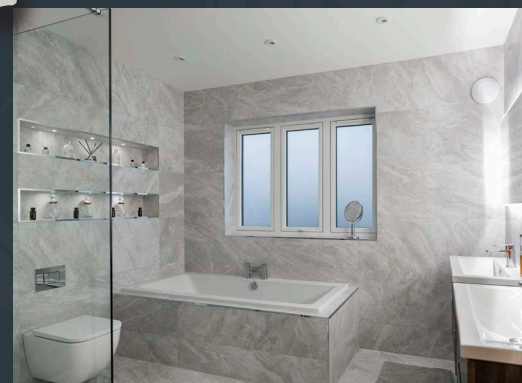



SCAN THE QR CODE TO WATCH
THE FULL VIDEO

scan me!

The look of Residence 9 windows perfectly replicated traditional manufacturing methods as an alternative to timber



Working peg & stay



The Lyme Park Residence

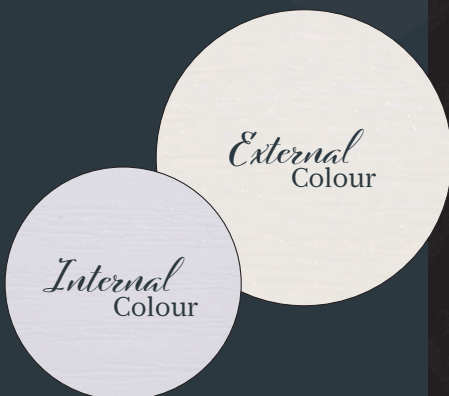

Windows	Residence 9
Installer	Alexander Windows Ltd
Location	Lyme Park
Manufacturing Method	Mechanical joints on sash and frame
Configuration	Casement windows, with a mixture of opening and dummy sashes. All with horizontal Georgian bar to replicate previous windows.
Colour	External: Clotted Cream Internal: Grained White
Glazing	28mm decorative bead

Preserve Kerbside Appearance

If you are looking for kerbside appeal, look no further. The flush sash exterior is timeless and a true recreation of traditional 19th Century timber windows and doors. This is achieved by mirroring the sizes historically documented and as listed in Article 4 directions. Furthermore, all the glass sightlines are perfectly equal providing symmetry and style. The internal shape and depth is completely authentic and gives an elegant and distinctively deep appearance.



CASE STUDY: SCARBOROUGH COLLEGE

This beautiful 14-acre site in the seaside town of Scarborough has been committed to the highest standards of education for over 100 years for children aged 3 - 18.

Specified for its authentic timber aesthetic, R9 in our classic colour choice Grained White was the perfect fit for this Grade II listed building.

Residence 9 is the ultimate timber alternative system, also achieving one of the highest classifications of British Standard weather tests due to its robust design and market leading thermal and acoustic values, far surpassing the British Building Regulation requirements. The result is a heritage building restored to the highest standards, not only sympathetic to its rich history, but with unbeatable performance too.

- Class 4 Air Permeability; Class E900 Water Tightness; Class B5 3000Pa Exposure
- Recycled sections for enhanced screw retention and galvanised steel sections optimised for strength
- 44mm glazing can achieve up to A++ or 0.74 W/m²K and 28mm glazing can achieve up to A or 1.23 W/m²K

Before



After



Windows	Residence 9
Installer	Centurion Windows
Location	Scarborough
Manufacturing Method	Mechanical joints on sash and frame
Configuration	Open out French windows featuring horizontal Georgian bars. Finished internally with black monkey tail hardware.
Colour	External: Grained White Internal: Grained White
Glazing	28mm decorative bead



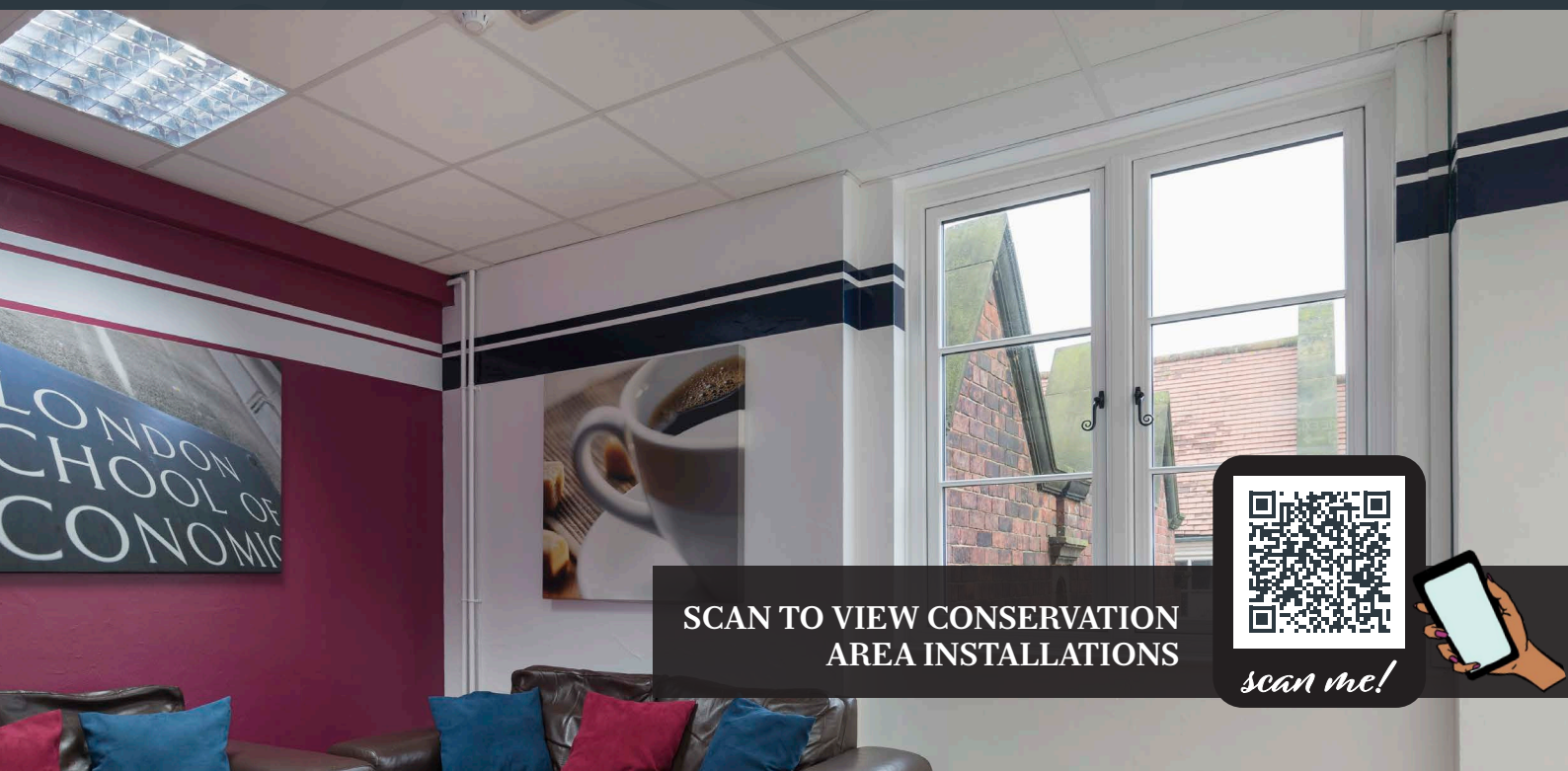

SCAN TO VIEW CONSERVATION
AREA INSTALLATIONS



scan me!



Genuine Heritage Design

19th Century timber windows were hand crafted and in order to truly replicate the features of this window style, The Residence Collection combines modern machining processes with the eye of a craftsman. A range of authentic styles and configurations, allows you to recreate and preserve traditional details, redefining modern windows and doors.

TRADITIONAL SIGHTLINES

Flush sash authentically replicates 19th Century timber window and door aesthetics, maintaining equal sightlines.

GEORGIAN BAR

The Residence Collection has bespoke sections that typically replicate deep decorative detailing inside and the chamfered putty line outside. With the Georgian bar you can recreate the pattern of the original windows to preserve your home's character or add new personality with the flair of designing your own patterns.

TRADITIONAL HARDWARE

Inspired by the appearance of 19th Century ironmongery, the Regal handles and stays enable you to replace your windows without losing the character of your home. Available in a range of nine exclusive finishes, our handles come with the added security benefit of key locking and working or dummy matching stays are available. Complete the authentic look with black or white butt hinges, these can be traditionally working or dummy for use with modern hinges.



HISTORICAL SIZES

Flush Sash



Frame Depth
3 3/4" (95mm)

Sash Sightline
2 1/2" (65mm)

Frame Sightline
2 1/2" (65mm)

RESIDENCE 9 SIZES

Flush Sash



Frame Depth
4" (100mm)
covers old paint
line



SCAN TO SEE OUR FULL RANGE
OF HARDWARE

scan me!

AUTHENTIC CILL DETAIL

The Residence Collection offers a range of cills, if you are replacing an old timber cill 'The Radlington' is the modern interpretation of a timber cill and therefore the perfect choice. It is designed to authentically accompany your windows and doors so you can recreate that stunning traditional look.



*The Radlington cill
55mm x 165mm*



*The Radlington cill
30mm x 165mm*

BEST OF
British



RANGE OF CILLS

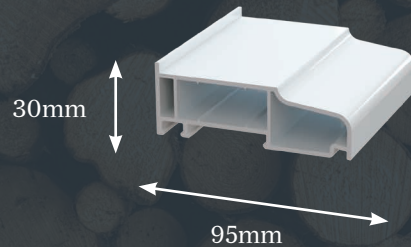
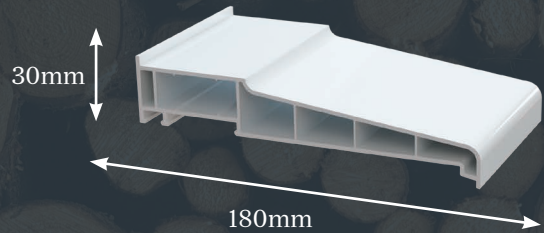

THE RADLINGTON CILL

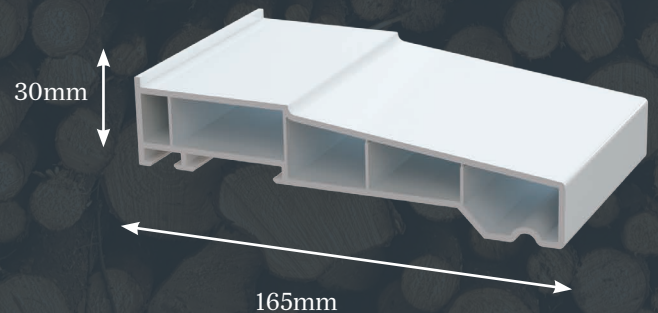
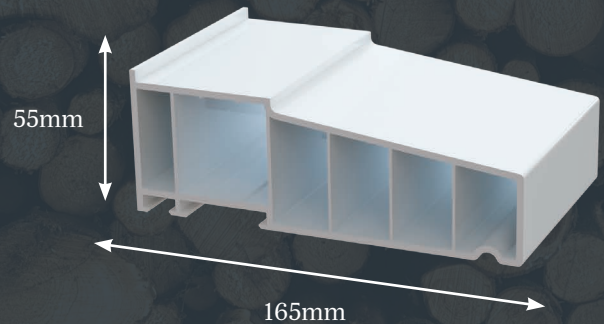



“Georgian bars and weatherbar add historic detailing to the windows”

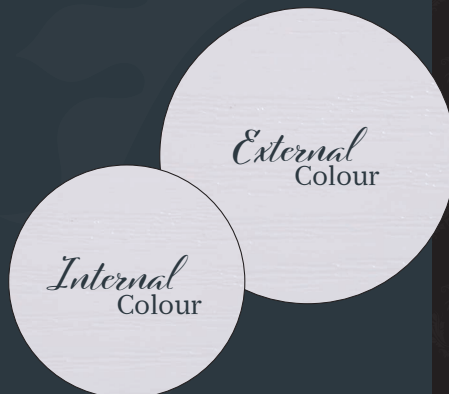

Windows	Residence 9
Installer	Homelink Direct Ltd
Location	Sewell Park
Manufacturing Method	Graf weld / seamless weld
Configuration	A mixture of dummy and opening sashes, opening were top hung. With the addition of Georgian bars and external weatherbar, perfectly replicated previous timber windows.
Colour	External: Grained White Internal: Grained White
Glazing	28mm square bead



*R9 was the perfect fit
for this Oast house.
Perfectly mirrors the
sizes as historically
documented & listed in
Article 4 directions*

R9



Grained White

Grained white is extremely versatile and suits all homes, this is why it's our most popular finish. Offering a traditional brilliant white painted timber look, it represents harmony and balance.





No 10. Black
 Named after the famous Downing Street door. It is imposing and authoritative looking, a staple and fashionable colour for many. It can make your property feel both dramatic and welcoming.



R9 in No.10 Black
 maintains the
 quaint heritage
 look of this
 thatched cottage

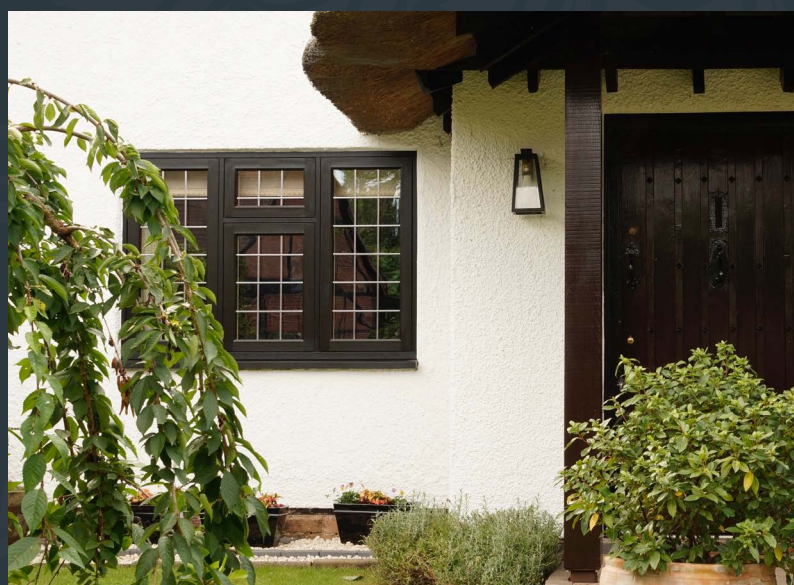

R9

Conservation Area Approved

Over the years, The Residence Collection windows and doors have been widely accepted in conservation areas and Grade II listed buildings across the UK.

If you are looking for support with your planning application we have some resources you might find useful, including CAD files for the different profiles, case studies and a full list of areas in the UK where The Residence Collection has been accepted.



“The windows have been designed for timber replacement & aesthetically they look the part”

NCHA Property Services



Conservation
Area Installation



Grade II Listed
Installation

Look out for these icons when searching for an installer on our website. This means they will have experience in fitting The Residence Collection in conservation areas and/or listed buildings.



“It's not timber, it's something better!”

Beautiful low maintenance timber alternative



Before



Timber windows in need of some TLC



Fully flush sightlines maintain the traditional aesthetic



After

Windows	Residence 9
Installer	Perfect Choice
Location	Howle Hill
Manufacturing Method	Mechanical joints
Configuration	Side-hung windows with a single horizontal Georgian bar & floating mullion was specified to create a French window.
Colour	External: Cotswold Green Internal: Grained White
Glazing	28mm decorative bead



External Colour



Internal Colour



Traditional Colours & Homes

Recreate or maintain heritage aesthetics with The Residence Collection.

Mix and match for the perfect Tudor mock look - Grained White sash with a No.10 Black frame and transom mullions. Match your corner-posts for a decorative look, and add leaded glass for the ultimate heritage aesthetic.

Corse Lawn is beautiful against Cotswold stone, whilst Grained White can perfectly replicate the prestige painted look of a manor house and English Oak can revive a sophisticated country barn.





YOUR HOME
YOUR WAY





WINDOWS & DOORS

THE WAY THEY'RE
MEANT TO BE™



**Conservation
Area Installation**



**Grade II Listed
Installation**

Look out for these icons when searching for an installer on our website. This means they will have experience in fitting The Residence Collection in conservation areas and/or listed buildings.

 Printed On Recycled Paper

THE
RESIDENCE
COLLECTION

Get in Touch

T: 01452 300912 W: [residencecollection.co.uk](https://www.residencecollection.co.uk) E: journey@residencecollection.co.uk



#myresidence #residencecollection

The Residence Collection is a registered UK trademark of Window Widgets Limited. © Copyright 2023.

*Your chosen installer should do a professional survey and advise on the suitability of The Residence Collection in your property and/or area.